

TAG4 CART

CART INSTALLATION INSTRUCTIONS

* HDWE- TAG4 CART (23487)			
5	11368	8	WASHER- 5/16 FLAT STNLS
4	20840	4	NUT- 5/16-18 NYLOC STNLS
3	23489	4	BOLT, 5/16-18 X 2 HXHD STNLS
ITEM	PART#	QTY	DESCRIPTION

2	23487	1	HDWE- TAG4 CART *
1	23484	1	CART ASSY- TAG4
ITEM	PART#	QTY	DESCRIPTION

TOOLS: - DRILL - 1/2" DRILL BIT - 1/2" WRENCHES (2)

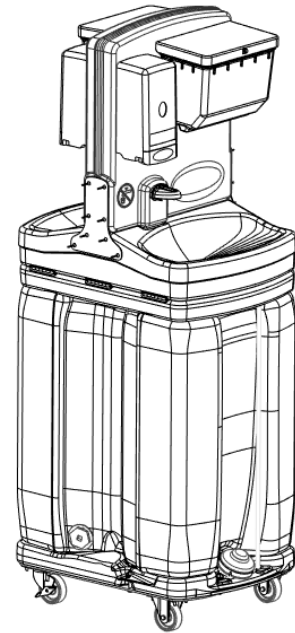

ASSEMBLE CART TO SINK

1. Drill (2) holes with 1/2 inch drill bit at indicated locations in sink base.
2. Place sink on cart and align holes.
3. Insert bolts with washers through holes from below.
4. Tighten nuts and bolt until snug. *Do not over tighten.*

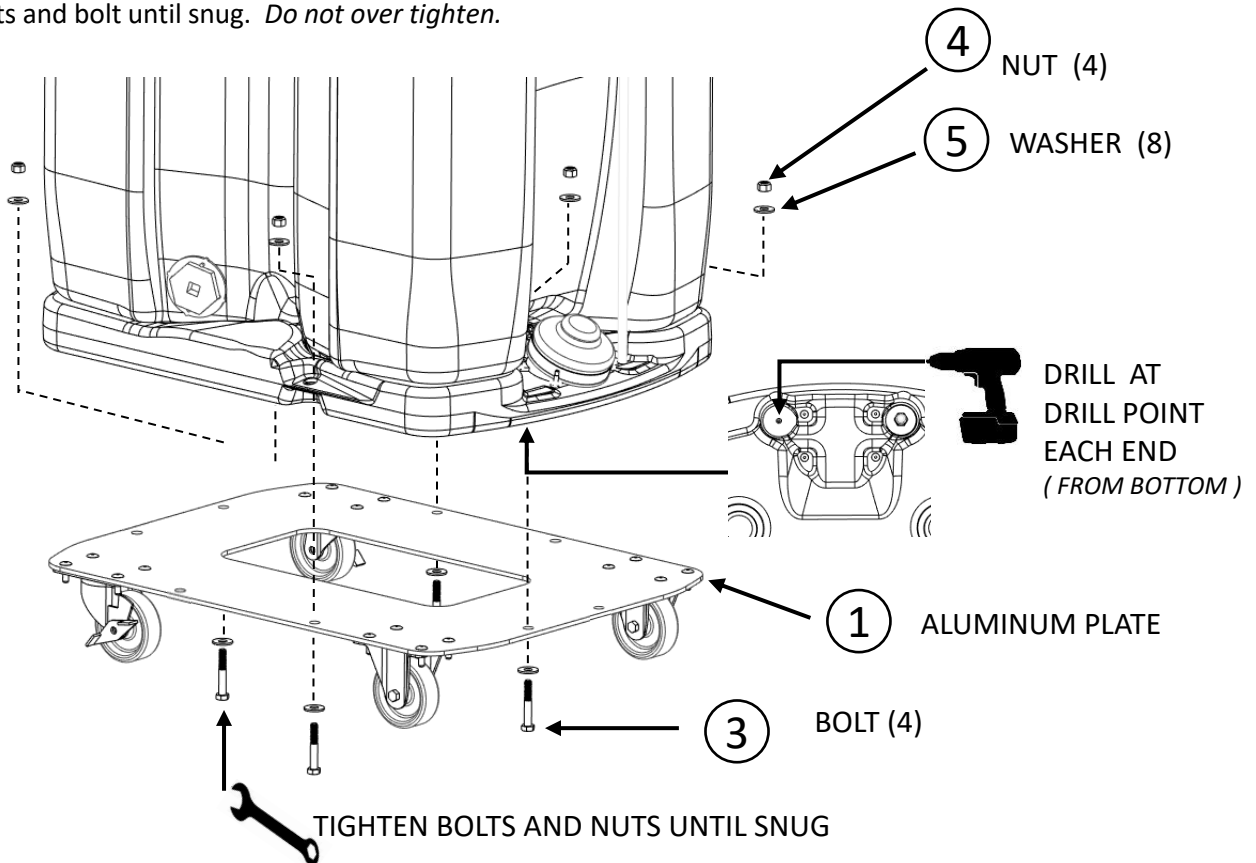

** SEE PAGE 2 OR 3 IF CART REQUIRES ASSEMBLY **



2530 Xenium Lane North, Minneapolis, MN 55441
 Telephone: 763-553-1900 Fax: 763-553-1905
 800-328-3332 / www.satelliteindustries.com

CART ASSEMBLY WITH BOLTS

CART ASSY- TAG4 (23484)			
ITEM	PART#	QTY	DESCRIPTION
6	23604	16	NUT- 1/4-20 NYLOC THIN STNLS
5	1910-699	16	BOLT: 1/4-20 X 3/4 L 18-8
4	23485	1	PLATE- TAG4 CART
3	23487	1	HDWE- TAG4 CART (SEE PAGE 1)
2	1314-699	2	CASTER- 3" LOCKING SWIVEL
1	23486	2	CASTER- 3" RIGID

ASSEMBLED CART

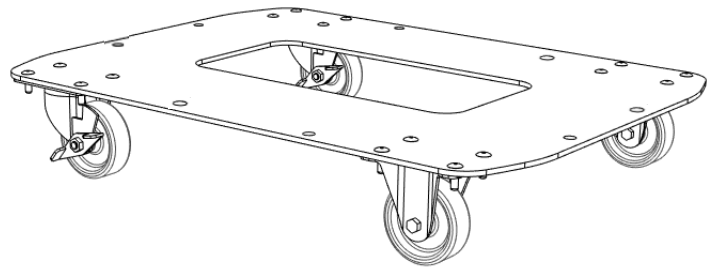

TOOLS: - 7/16" WRENCHS (2)

ASSEMBLE CART TO SINK

1. Place Caster on aluminum plate.
2. Align holes and fasten in place, use (4) Bolts, (4) Washers and (4) Nuts per caster.

Notes:

- *Bolt must be installed from top and Nut with Washer must be on caster side (see below).*
 - *Loosely install all 4 bolts with washers and nuts on a caster before tightening any of them.*
3. Tighten nuts and bolts on each caster.
 4. Repeat process for remaining Casters.
- Note Rigid Casters are to be placed at one end and the Swivel casters at the other. (see below)*

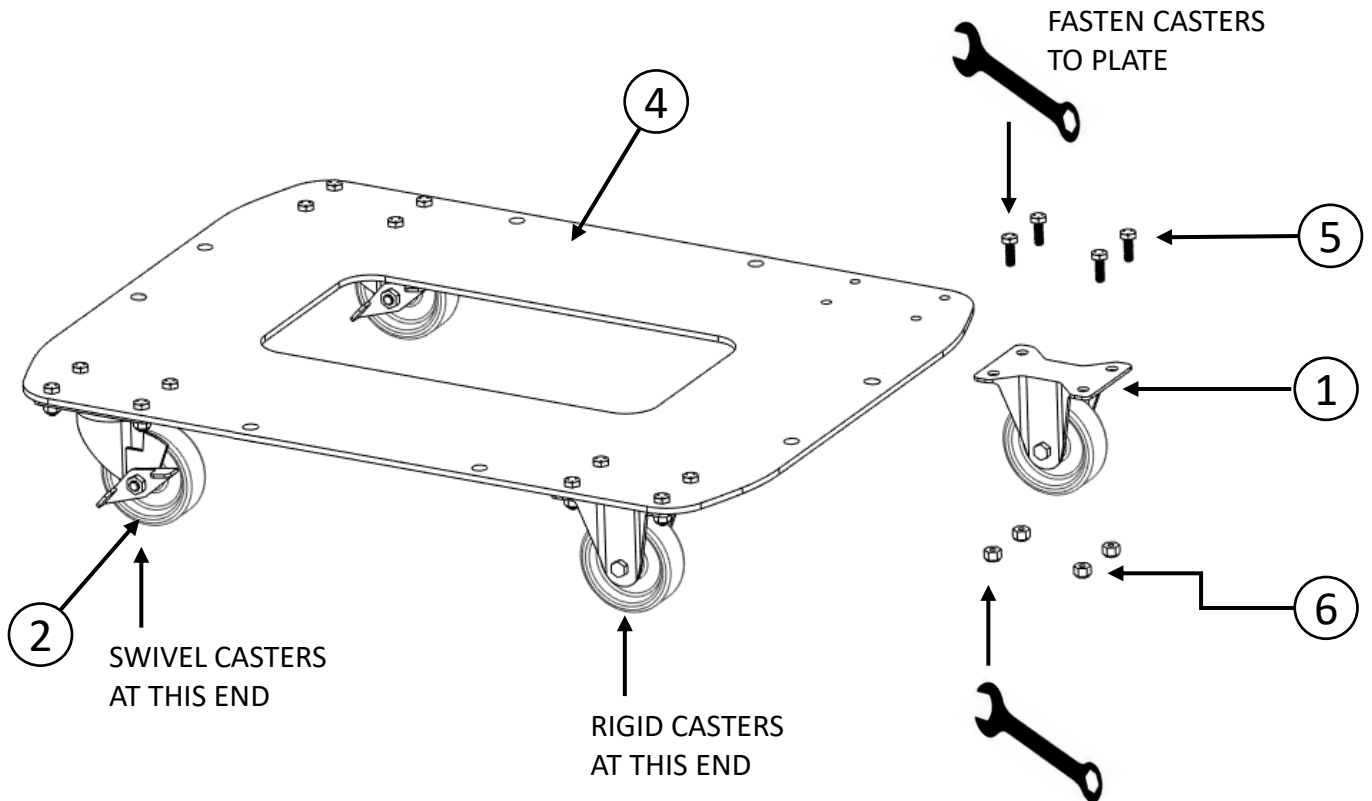

CART ASSEMBLY WITH RIVETS

CART ASSY- TAG4 (23484)			
ITEM	PART#	QTY	DESCRIPTION
6	1316-699	16	WASHER: BLIND RIVET ALUM.
5	1315-699	16	RIVET: AB8-6 1/4" DIA. ALUM.
4	23485	1	PLATE- TAG4 CART
3	23487	1	HDWE- TAG4 CART (SEE PAGE 1)
2	1314-699	2	CASTER- 3" LOCKING SWIVEL
1	23486	2	CASTER- 3" RIGID

TOOLS: - RIVET GUN

ASSEMBLED CART

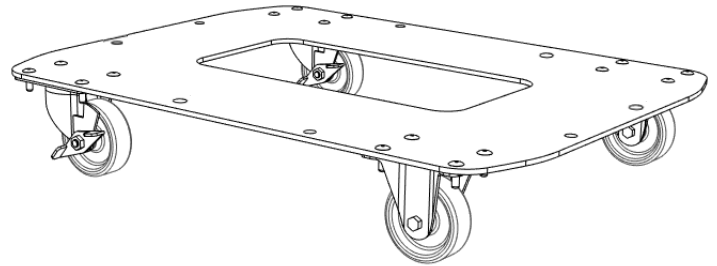

ASSEMBLE CART TO SINK

1. Place Caster on aluminum plate.
2. Align holes and fasten in place, use (4) Rivets, and (4) Washers per caster.
Note Rivet must be installed from top and Washer must be on caster side (see below).
3. Repeat process for remaining Casters.
Note Rigid Casters are to be placed at one end and the Swivel casters at the other. (see below)

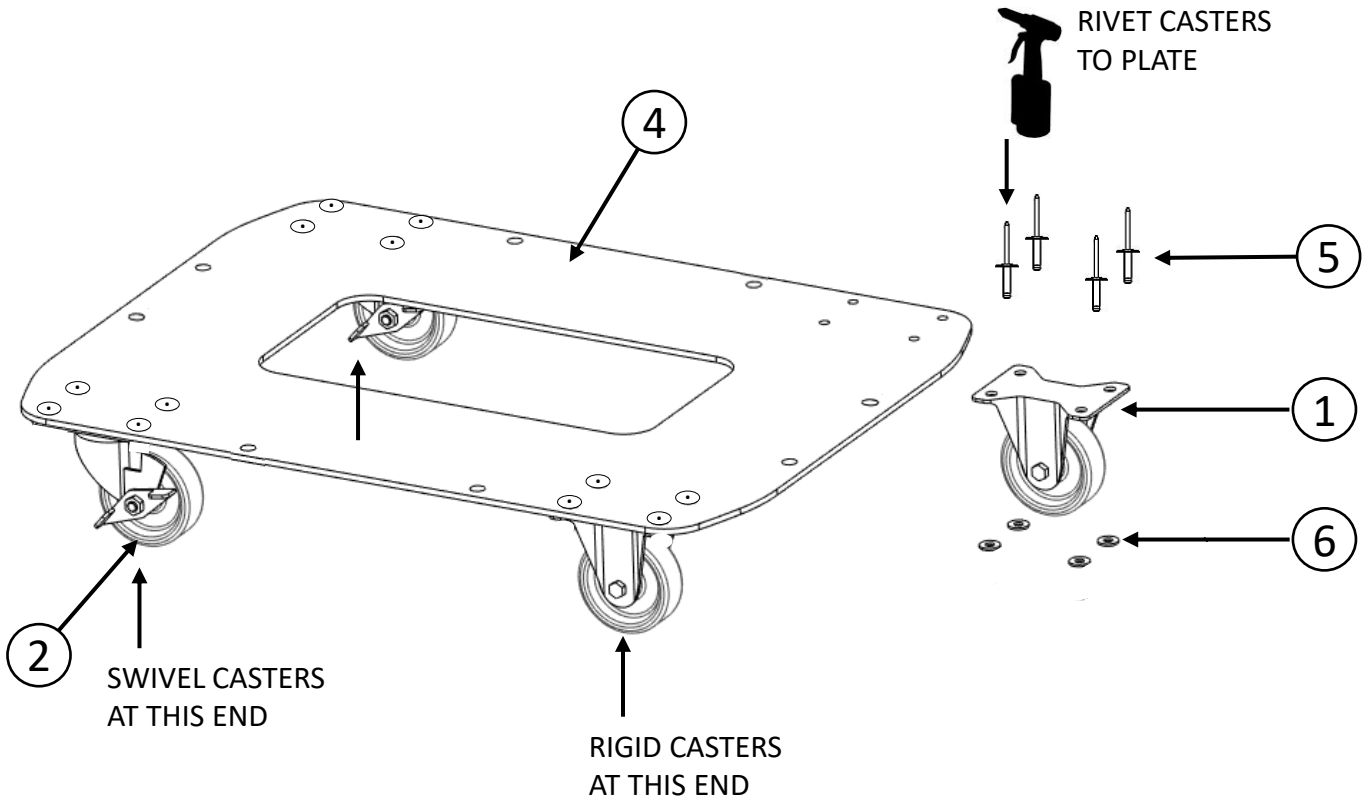

2530 Xenium Lane North, Minneapolis, MN 55441
 Telephone: 763-553-1900 Fax: 763-553-1905
 800-328-3332 / www.satelliteindustries.com